



<b>Type</b> <b>2625 02 i</b>	<b>Manual</b>	<b>solo</b> <sup>®</sup> KLEINMOTOREN GMBH Stuttgarter Str. 41 D 71050 Sindelfingen, Germany
---------------------------------	---------------	---

## Table of contents

	page
Cover page	1
Log of revisions	1
Table of contents	2
1. General engine description	2
2. Technical data	2
3. Operational data and limitations	3
4. Redundancy system	3
5. Installing Instructions and torques	3
6. Operating instructions	4
7. Maintenance instructions	5
8. Trouble shooting	5
9. Wiring diagrams and fuel supply system	6
10. Power sheet	9

## 1. General engine description

- Twin - cylinder in line - two - stroke - engine
- Liquid cooling
- Lubrication by fuel-oil-mixture
- Electronic fuel injection
- Dual electronic high-voltage ignition
- Redundancy system
- Crankshaft layout for belt transmission
- AC generator

## 2. Technical data

Displacement	625 cm <sup>3</sup> bore 76 mm    stroke 69 mm
Compression ratio	9,5 : 1
Ignition unit	Dual electronic high-voltage ignition, mapped
Spark plugs	BOSCH W5 AC, air gap at electrodes 0.5 mm
Fuel injection	Electronic, two butterfly shutters, mapped
Sense of rotation	Clockwise in flight direction
Fuel	Premium unleaded Min. 95 RON , AVGAS100LL, or mixtures of the two fuels
Lubrication	Fuel oil mixture 1:50 (2%), Oils according to the specification JASO FC or FD, recommended oil Castrol ACT>EVO
Dry weight	24 kg without exhaust (according to airframe manufacturer)
Generator	12 V 500 W
Coolant	Engine coolant (Glysantin BASF G48), tap water (0-20°dh) in a mixture of 40:60 (27°C)

<b>Type</b> <b>2625 02 i</b>	<b>Manual</b>	 <small>KLEINMOTOREN GMBH  Stuttgarter Str. 41  D 71050 Sindelfingen, Germany</small>
---------------------------------	---------------	---

### 3. Operational data and limitations

Take-off-speed, power	6 600 rpm with a power of 50 kW (68 hp)
Max. cont. speed, power	6 600 rpm with a power of 47 kW (68 hp) /
Max. rpm	6 700 rpm
Cut off speed by CPU	6 700 rpm
Idle rpm	approx. 2 300 rpm
Max. temp. cooling liquid	115 °C (240°F) measured in the cylinder - head
Fuel consumption	Max. continuous power approx. 24,5 l/h

### 4. Redundancy system

In order to assure a safe mode of operation a redundancy system was developed, which can be manually activated if the normal engine control breaks down. It consists of a simple ECU, which contains a characteristic diagram. This diagram (fuel supply over engine speed) controls two additional injection valves. The fuel is guided through two hoses into the manifolds. The engine speed and the fixed ignition timing are detected by an additional inductive sensor. The ECU has two ignition controllers which control the two ignition coils, which are also used for the normal engine operation. The system has no correction for air pressure and temperature. The engine operational data and limitations are unchanged if the engine is operated with this system. The weight is approx. 300 g.

### 5. Installing Instructions

The engine can be mounted at the drive side flange with 4 bolts M8. At the cylinder heads there are 4 more threads M8 and at the bottom of the crankcase there are 4 threads M10. The cylinders have to be in vertical position when the engine is in its operating position. The load on the mounting threads can be 5 kN each.

The fuel line has to be protected against fire.

A fuel pump with a fuel pressure of min. 3.5 bar and a maximum pressure of 5 bars is to be used. In the return line a fuel pressure regulator has to be installed which regulates the fuel pressure to 3 bars.

Upstream to the fuel pump a fuel filter with a mesh size of 60 to 100 µm has to be installed. After the pump a micro filter with a mesh size of 10 µm has to be installed. (A suggested fuel scheme see chapter 9)

A water cooler with a cooling capability of 16 kW has to be used.

If an electric starter is used, its power has to be at least 400 W.

If the propeller is driven by a belt the belt tension may not be higher than 5 000 N

For the electrical wiring see the diagrams in chapter 9.

For the redundancy system an inductive sensor (Bosch No. 0 261 210 147) has to be mounted at the engine mount, that this sensor is in line with the two pins situated on the starter gear and an ignition timing of 22 degrees before TDC is achieved.

<b>Type</b> <b>2625 02 i</b>	<b>Manual</b>	 <small>KLEINMOTOREN GMBH  Stuttgarter Str. 41  D 71050 Sindelfingen, Germany</small>
---------------------------------	---------------	---

## Table of torques

Spark plug	20 Nm
Drive pulley on crankshaft	100 Nm
Bolts and nuts M 6	12 Nm
Bolts and nuts M 8	20 Nm
Bolts and nuts M 10	40 Nm
Magneto on crankshaft	80 Nm

## 6. Operating instructions

For correct function of the engine it is absolutely necessary to follow exactly the following operating and maintenance instructions.

Before starting the engine	<p>Has daily check been made?  Open throttle lever fully. Check throttle lever for free movement on full range.  Ignition: „OFF". Turn propeller several times by hand to check for abnormal noise or hard motion of the engine.  Move throttle lever to idle position</p>
Starting the engine	<p>Main switch on. Throttle lever in idle  Open fuel cock. CPU and ignition "ON".  Check for safety around the propeller. Engage the wheel brake.  Start the engine.</p>
Take off and climbing	<p>Conduct an ignition check at approx. 4 000 RPM .Maximum rpm - drop 300 RPM.  Check the redundancy system at 4 000 RPM. After a short RPM drop the engine should run at the same RPM level. Switch back to normal operation mode.  Accelerate to full throttle.  Limits of RPM - level and temperatures may not be exceeded.</p>
Stopping the engine	<p>Switch off ignition.</p>
Starting the engine in flight	<p>Move the engine into flight position. Disengage the propeller stop. Throttle in idle position. Fuel cock open. CPU and ignition "On". Start until engine runs. Throttle into full.</p>

<b>Type</b> <b>2625 02 i</b>	<b>Manual</b>	 <small>KLEINMOTOREN GMBH  Stuttgarter Str. 41  D 71050 Sindelfingen, Germany</small>
---------------------------------	---------------	---

## 7. Maintenance instructions

Daily check before flight	Check fuel quantity. Check throttle lever for free movement. Check outside of engine, engine compartment, belt transmission and mountings for proper condition. Check level of cooling liquid.
Inspection after 25 hours of operation or after 1 year.	Check spark plugs. Check entire engine for loose parts and bolts. Check all Bowden cables and controls. Check wires and electrical connections. Check belt tension. Put grease on starter gears.
Inspection after 400 hours of operation.	Inspection and overhaul by the manufacturer.
Conservation and storage of the engine.	If the engine is stored for more than 2 months or it is out of use, preserve and store it as follows: Inject approx. 2.5 ml of two stroke oil into each throttle body and crank the engine 10 turns by hand. Cover intake openings on carburetors.

## 8. Trouble shooting

### Engine does not start

No fuel supply	Check fuel line to the injectors. Check function of fuel pump.
No spark on both spark plugs of ignition circuit	Weak battery. Charge battery. Defective wires or ignition coil defective.
No spark on one spark plug of ignition circuit	Defective spark plug. Defective wires or ignition coil.

### Engine does not run properly

Engine gets too hot	Cooling liquid level low. Water pump faulty. Fuel pressure not sufficient.
Engine does not reach full rpm	Fuel pressure not sufficient. Fuel filter clogged. Throttle does not open completely. Defective fuel pump. Defective spark plugs.

### Failure memory

The ECU has a failure memory, which detects and stores failures of the system. This memory can only be checked by the manufacturer. For a check please send the ECU to the manufacturer

## 9. Wiring diagram

### Connection of the ECU to the engine

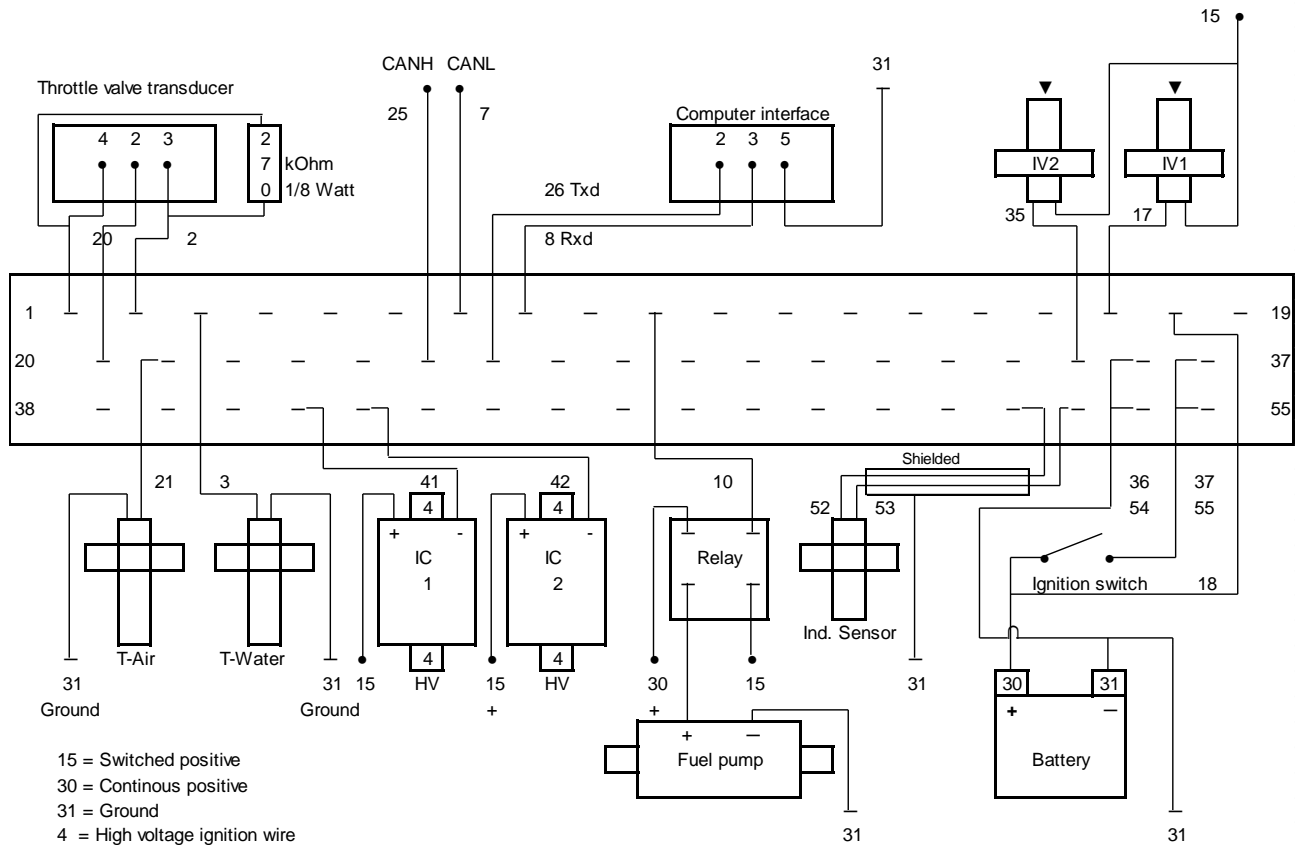

#### Plug connection ECU

<p>1 Ground throttle valve transducer          20 5 Volts throttle valve transducer          2 Signal throttle valve transducer</p> <p>7 CAN L (CAN bus)          25 CAN H (CAN bus)</p> <p>8 Computer interface Rxd          26 Computer interface Txd</p> <p>17 Injection valve 1 (Alternator side)          35 Injection valve 2 (Drive side)</p> <p>21 Temperature transducer air          3 Temperature transducer coolant</p>	<p>41 Ignition coil 1 (Alternator side)          42 Ignition coil 2 (Drive side)</p> <p>10 Relay fuel pump</p> <p>53 RPM transducer (Induktive)          54 Ground RPM transducer</p> <p>36 Ground          54 Ground</p> <p>37 Switched positive          55 Switched positive</p> <p>18 Continuous positive (optional)</p>
---	--

## Redundancy system

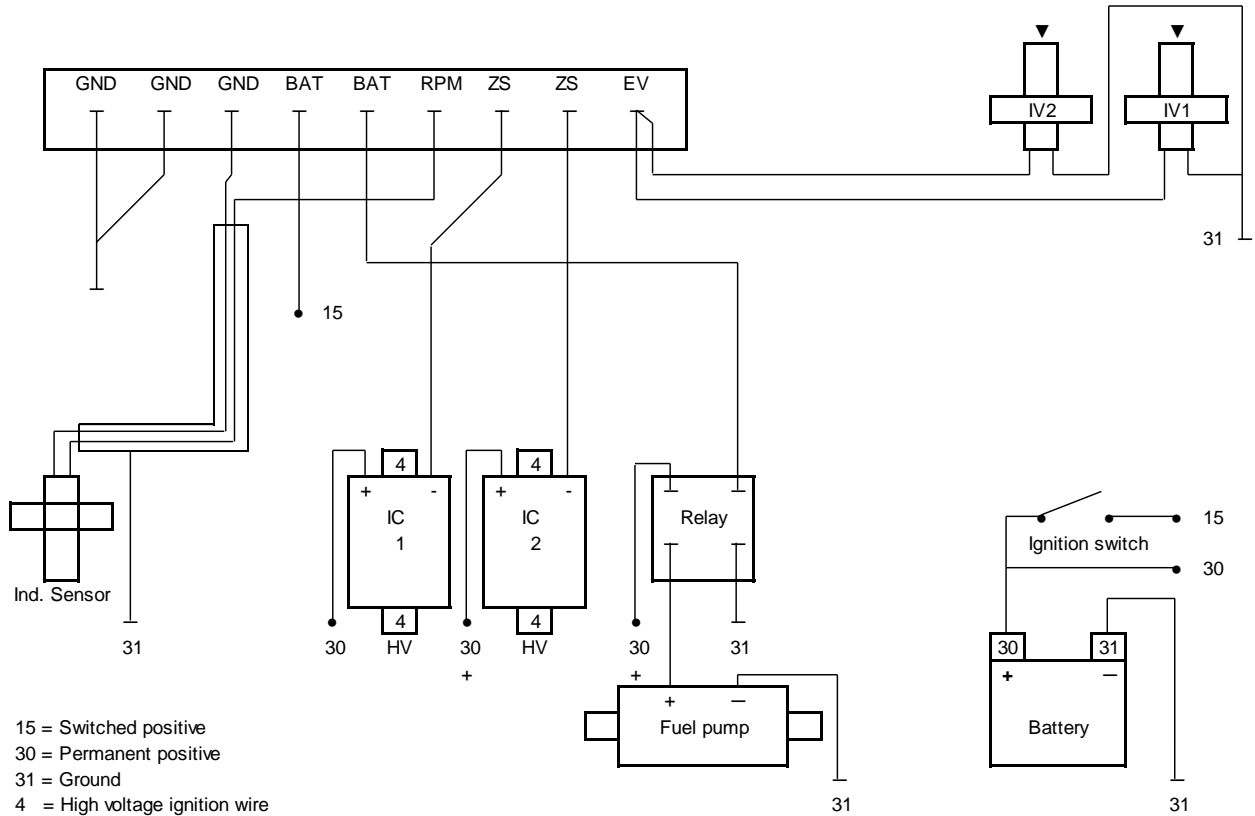

### Plug connection Redundancy System

BAT : Switched positive  
 BAT : Switched positive

GND : Ground  
 GND : Ground

EV : Injection valve 1 and 2

ZS : Ignition coil  
 ZS : Ignition coil

RPM : RPM sensor  
 GND : Ground RPM sensor

## Fuel supply system

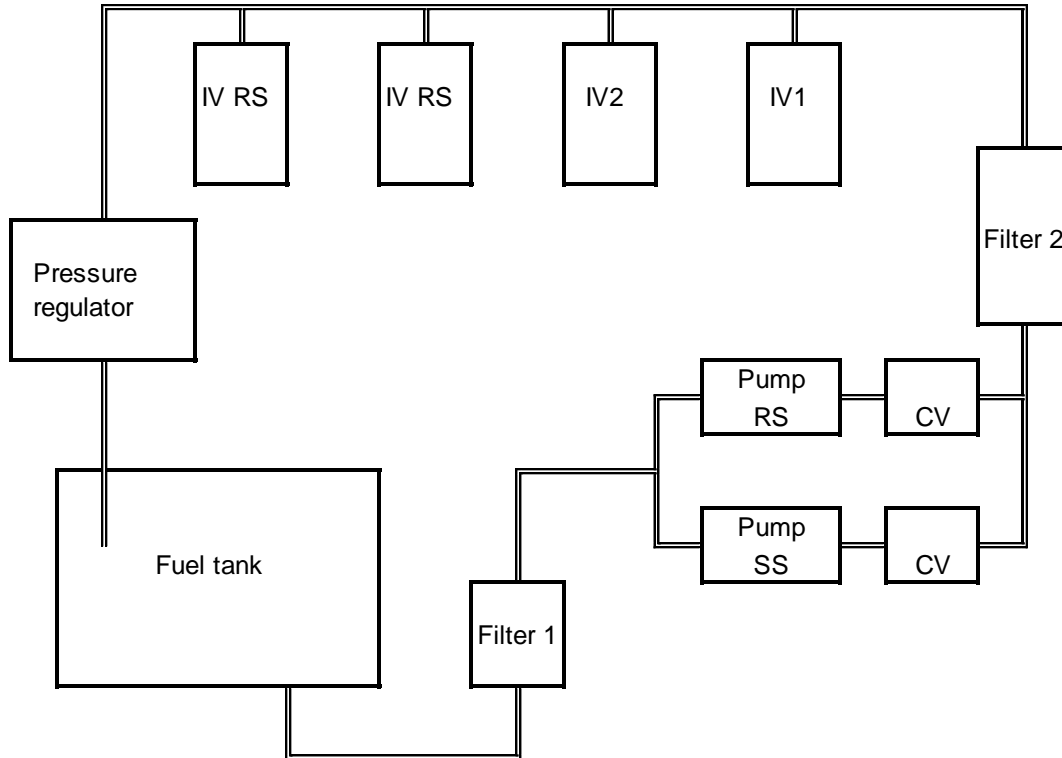

- IV 1 : Injection valve standard system generator side
- IV 2 : Injection valve standard system driveside
- IV RS : Injection valve redundancy system
- IV RS : Injection valve redundancy system
- Pump SS : Fuel pump standard system
- Pump RS : Fuel pump redundancy system
- CV : Check valve



## 10. Power sheet

